

# SALES & ENGINEERING DATA

RATIO SERIES: **1.2:1**

FLUID P.S.I. RANGE: **60 - 2670**

## 650941-XXE-C EXTRUSION PUMP

RELEASED: 9-21-01  
REVISED: 11-14-06  
REV. 03 S-1025

### DIMENSIONAL DATA

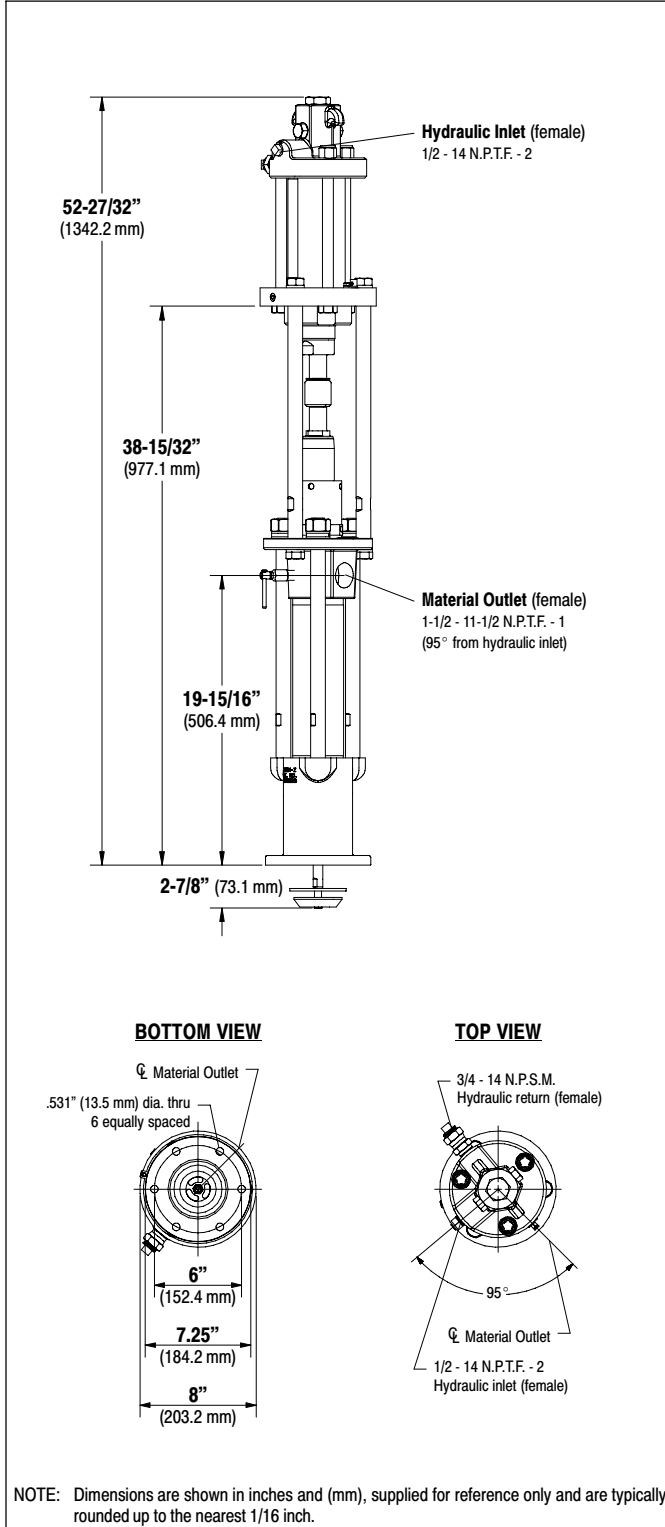

### SPECIFICATIONS

#### CONSTRUCTION

Model Series (refer to option chart)	650941-XXE-C
Pump Type	Hydraulic Operated, Extrusion, Double Acting Pump
Ratio	1.2:1
Hydraulic Motor	67314-B
Motor Repair Kit	637450
Motor Size	4.125 sq." (26.6 sq. cm)
Stroke	6" (15.2 cm)
Hydraulic Inlet (female)	1/2 - 14 N.P.T.F. - 2
Hydraulic Return (female)	3/4 - 14 N.P.S.M.
Lower Pump End Series	66236-XXE-B
Lower Pump Repair Kit	637128-XX4-B
<b>Packing Options:</b>	

3 - Glass filled Teflon
C - UHMW-PE
F - UHMW-PE / Leather staggered upper • UHMW-PE lower
J - Polyurethane upper • UHMW-PE lower
P - UHMW-PE / Glass filled Teflon staggered upper • UHMW-PE lower
R - Glass filled Teflon / UHMW-PE staggered upper • Glass filled Teflon lower

Material Outlet (female) 1-1/2 - 11-1/2 N.P.T.F. - 1

#### MATERIALS OF CONSTRUCTION

Outlet Body	Ductile Iron, Nickel plated
Cylinder	Carbon Steel, Nickel plated
Plunger	Carbon Steel, Chrome plated
Upper Check	440 Stainless Steel
Upper Seat	440 Stainless Steel
Lower Check	440 Stainless Steel
Lower Seat	440 Stainless Steel
Inlet Body	Ductile Iron, Nickel plated
Weight	144 lbs (65.3 kgs)

#### PERFORMANCE

Hydraulic Inlet Pressure Range	50 - 2000 p.s.i. (3.4 - 137.9 bar)
Fluid Pressure Range	60 - 2670 p.s.i. (4.1 - 184.1 bar)
Required H-power @ 50 c.p.m.	3.2 @ 1200 (82.8 bar)
Hydraulic flow req'd @ 50 c.p.m.	8.7 g.p.m. (32.9 l.p.m.)
Maximum Rec'd Cycles / Minute	50
Displacement In <sup>3</sup> Per Cycle	40.2
Volume / Cycle	22.3 oz. (658.4 ml)
Cycles Per Gallon	5.7
Flow @ 50 Gallon / Minute	8.7 g.p.m. (33.1 l.p.m.)
Noise Level	N / A
Maximum Temperature Limit	130° F (54° C)

#### ACCESSORIES:

- 62151 Wall Mount Bracket
- 65139 Floor Mount

**PERFORMANCE CURVES**

